

DV5200 Series

Tubeaxial

127x127x38mm



- DC fans with electronically commutated external rotor motor. Fully integrated commutation electronics. With electronic protection against reverse polarity, blocking and overloading.
- Metal fan housing, impeller of fiber-glass reinforced plastic PA.
- Mounting from either face using four 4.3 mm holes.
- Air exhaust over struts. Rotational direction CCW looking at rotor.
- Electrical connection via leads AWG 22, TR 64. Stripped and tinned ends. Housing ground lug for screw M4 x 8 (TORX).
- UL, CSA, VDE approvals on some models, please contact application engineering.

Part Number	Curve	CFM @ 0	VDC	Volt. Range	Power (W)	dB(A)	Max Amb. Temp C	Bearing Type	Speed (RPM)	Wgt. (lbs)
DV5212N	1	158.9	12	9 to 13	20	56	65	Ball	5000	1.08
DV5214N	1	158.9	24	18 to 30	20	56	65	Ball	5000	1.08
DV5218N	1	158.9	48	36 to 53	22	56	65	Ball	5000	1.08

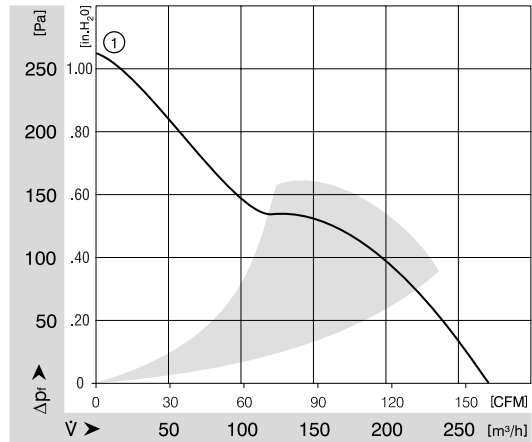
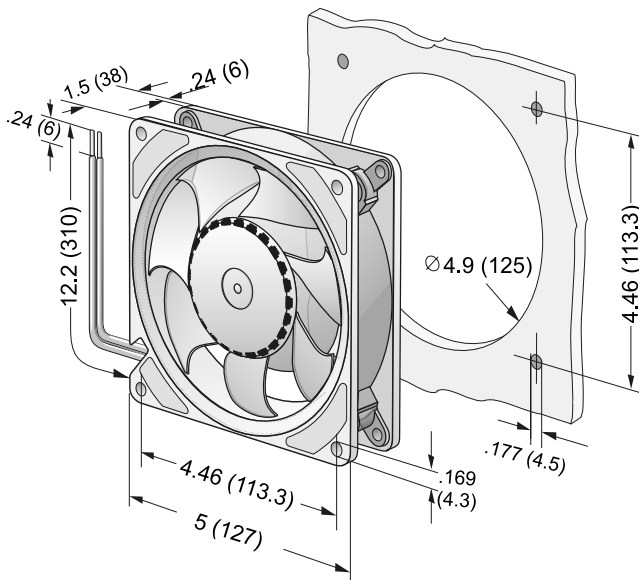

ebmpapst

e-mail: sales@us.ebmpapst.com · TEL: 860-674-1515 · FAX: 860-674-8536

ebm-papst Inc., 100 Hyde Road, Farmington, CT 06034 USA

ebm-papst Inc., 2005 © ebm-papst Inc. reserves the right to change any specifications or data without notice